

CAS #9800238  
 DETAIL 1

**CAMBRIDGEPORT**

8 FANARAS DRIVE SALISBURY MA 011952  
 PHONE 1-800-648-2872 FAX 978-499-0002

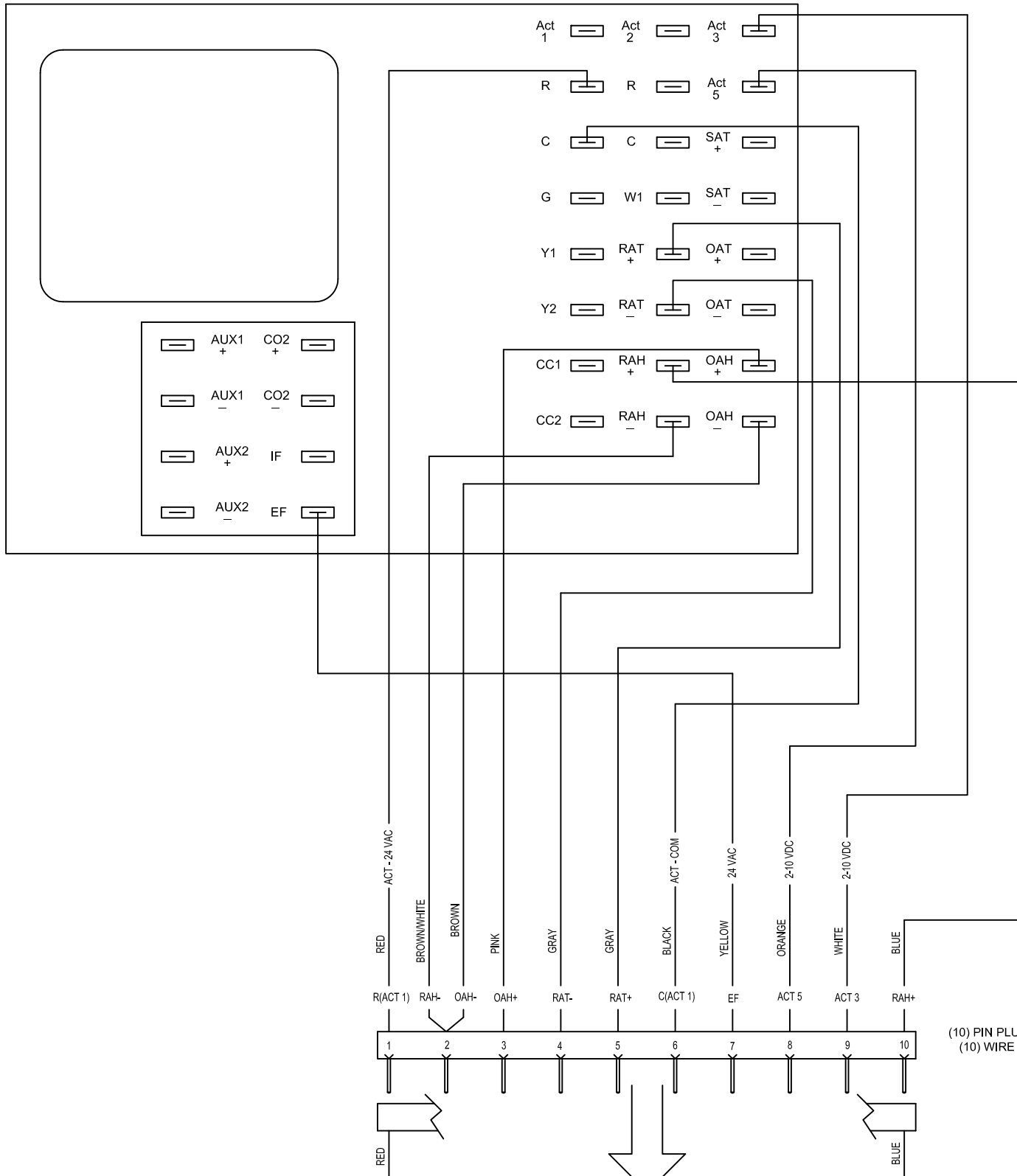

CAS #9800238  
 DETAIL 2

PLUG INTO FACTORY SUPPLIED  
 HARNESS THAT WAS REMOVED FROM  
 ECON SLOT ON UNIT CTB  
 \*\*\*NOTE ORIENTATION OF PLUGS\*\*\*

**CAMBRIDGEPORT**

8 FANARAS DRIVE SALISBURY MA 011952  
 PHONE 1-800-648-2872 FAX 978-499-0002

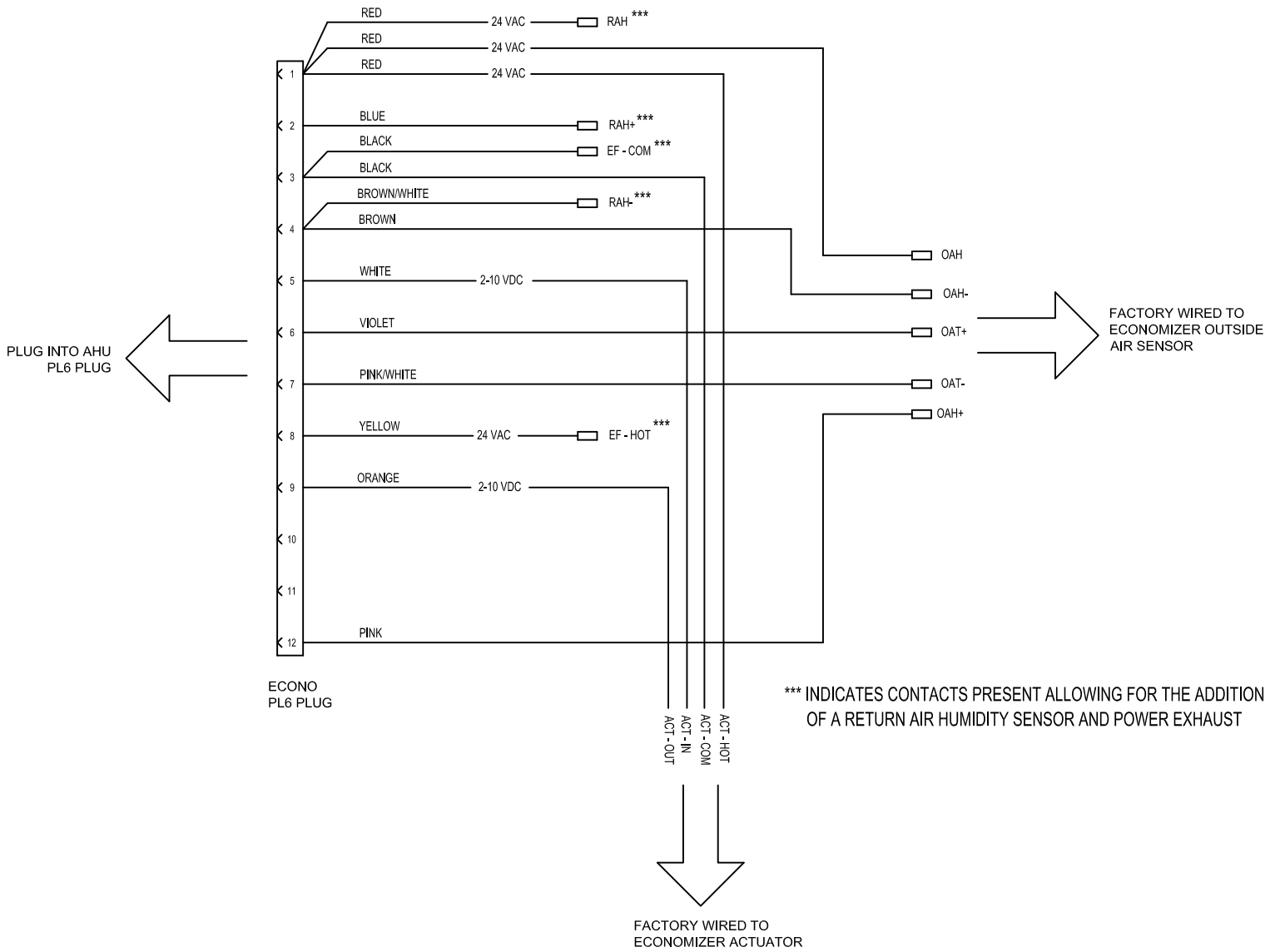

CAS #9800238  
 DETAIL 3

**CAMBRIDGEPORT**

8 FANARAS DRIVE SALISBURY MA 011952  
 PHONE 1-800-648-2872 FAX 978-499-0002