

DATE: _____
 COMPANY: _____
 JOB NAME: _____
 SUBMITTED BY: _____
 NOTES: _____

ROOF CURB SUBMITTAL #1001569

YORK 1RCO-437
 CURB ASSEMBLY NUMBER
 1001569

Drawn By: RTO
 Drawn Date: 01/25/07

REV:

ESTIMATED WEIGHT: 223 LBS.

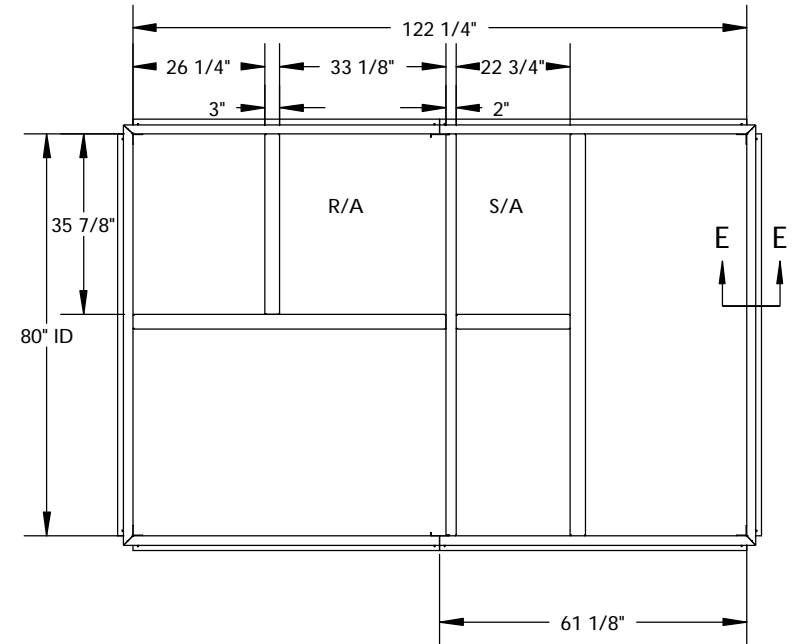
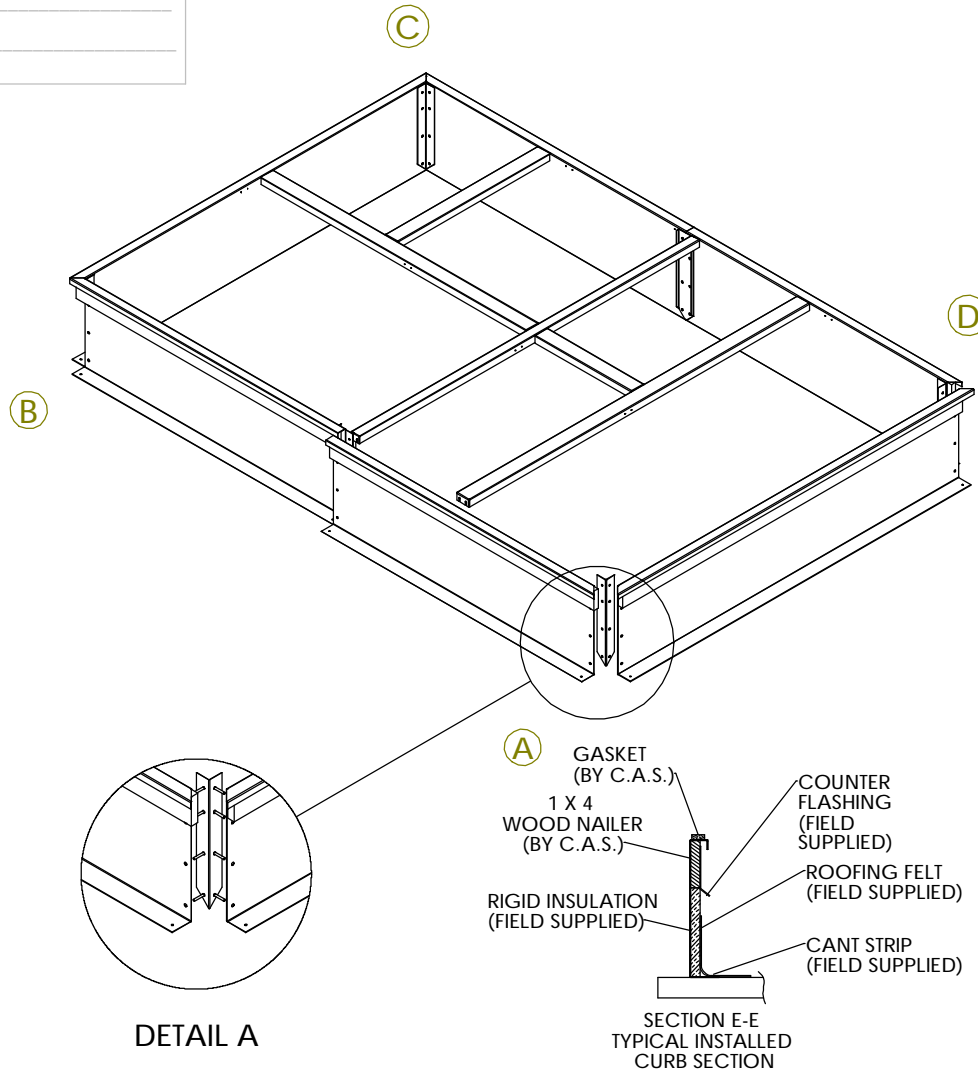

FEATURES:

MITERED TOP CORNERS

ROOF CURB BODY IS FABRICATED OF HEAVY GAUGE GALVANIZED STEEL.

FULL PERIMETER WOOD NAILER.

PRE-PUNCHED ASSEMBLY HOLES AND HARDWARE INCLUDED FOR DUCT SUPPORT INSTALLATION, ROOF CURB IS SHIPPED KNOCKED DOWN.

ROOF CURB IS LABELED WITH RTU# IF APPLICABLE
 SLOPE IS "SLOPE@SKETCH3@ENVELOPE.PART" PER FOOT

RTU#	HEIGHT OF CORNER A	HEIGHT OF CORNER B	HEIGHT OF CORNER C	HEIGHT OF CORNER D
	18"	18"	18"	18"

TM

Cambridgeport

AIR SYSTEMS, INC.

SALISBURY, MA 01952

PHONE 1-800-648-2872 FAX 1978-462-9189