

Cambridgeport

SUBMITTAL

SUBMITTED TO _____
 COMPANY _____
 JOB NAME _____
 EQUIPMENT _____
 SIGNATURE _____
 DATE _____

ROOF CURBS FOR TRANE ROOFTOP UNITS

YCD, TCD 181C, 211C, 240B
 YCD, TCD 241C, 300B, 301C
 WCD 240B

CAS	PART #		CURB HEIGHT "A"
	TRANE	INSULATED	
1000017	BAYCURB027	1005578	14"
1010033	N/A	1010034	8"
1005577	N/A	1005579	18"
1000238	N/A	1005580	24"

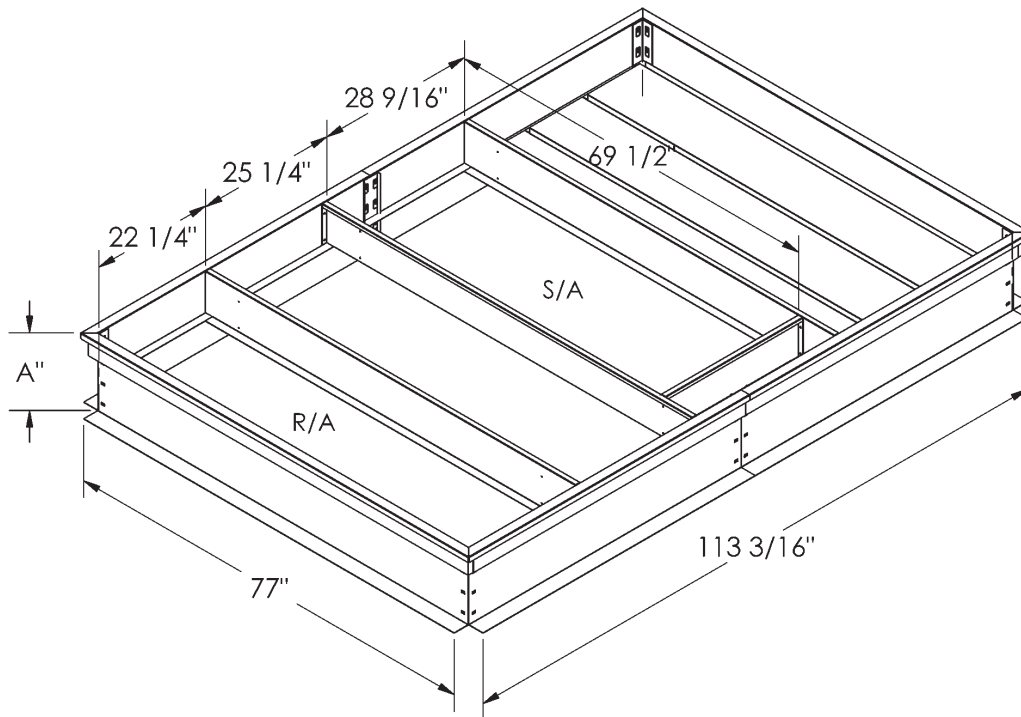

FEATURES

- MITERED TOP CORNERS
- ROOF CURB IS FABRICATED OF 18GA G90 GALVANIZED STEEL
- FULL PERIMETER WOOD NAILER
- PRE-PUNCHED ASSEMBLY HOLES AND HARDWARE INCLUDED FOR DUCT SUPPORT INSTALLATION
- ROOF CURB IS SHIPPED UNASSEMBLED
- * CURBS ARE INTERNALLY INSULATED WITH 1" THICK 1-1/2 LB DENSITY DUCT LINER

