

ISOLATION RAILS FOR CARRIER UNITS 48/50 PG 03-07

FEATURES

- MITERED TOP CORNERS
- FABRICATED OF ALUMINUM EXTRUSION
- FULL PERIMETER WEATHER SEAL
- 1" OR 2" STATIC DEFLECTION
- DUCT SUPPORTS INCLUDED
- INSTALLATION INSTRUCTIONS INCLUDED
- CANVAS DUCT CONNECTION NOT INCLUDED
- *KD- KNOCKED DOWN
- *ASD- ASSEMBLED

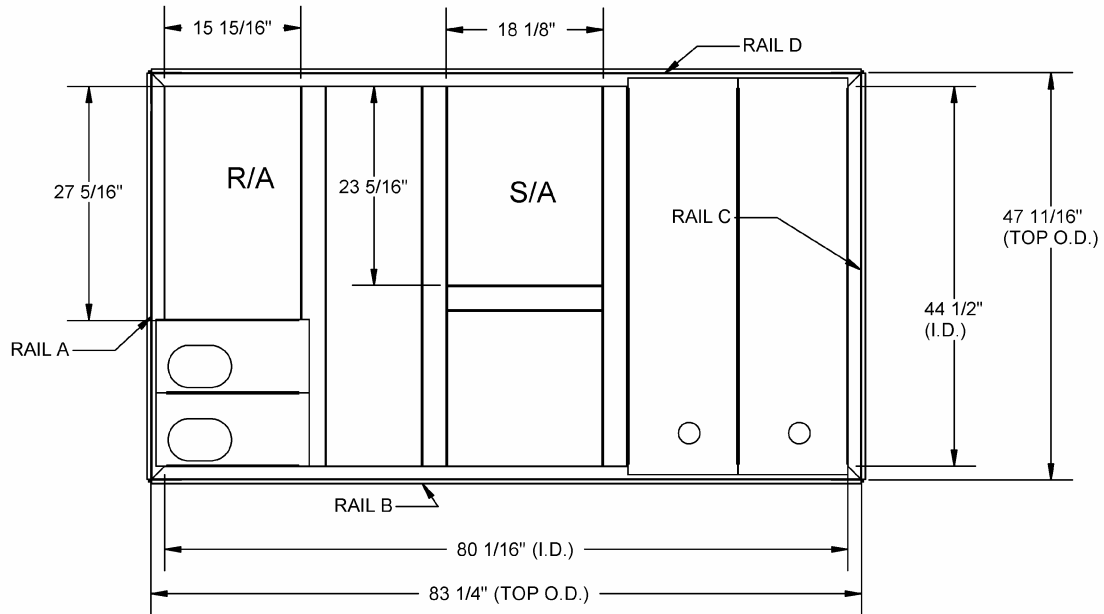
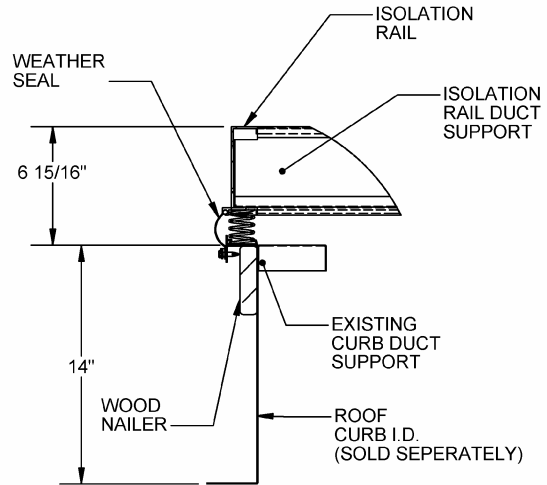

| PART # | | |
|--------------------|------------|---------|
| | DEFLECTION | C.A.S. |
| ISOLATION RAIL KD | 1 INCH | 1005892 |
| ISOLATION RAIL KD | 2 INCH | 1005893 |
| ISOLATION RAIL ASD | 1 INCH | 1005894 |
| ISOLATION RAIL ASD | 2 INCH | 1005895 |