

# Cambridgeport

## SUBMITTAL

SUBMITTED TO \_\_\_\_\_  
 COMPANY \_\_\_\_\_  
 JOB NAME \_\_\_\_\_  
 EQUIPMENT \_\_\_\_\_  
 SIGNATURE \_\_\_\_\_  
 DATE \_\_\_\_\_

## ROOF CURBS FOR TRANE ROOFTOP UNITS

YCD, TCD 121C, 151C, 180B, 210C  
 WCD 150B

PART #		PART #	CURB HEIGHT
CAS	TRANE	INSULATED	"A"
1000016	BAYCURB026	1005571	14"
1010016	N/A	1010017	8"
1003144	N/A	1005572	18"
1000231	N/A	1005573	24"

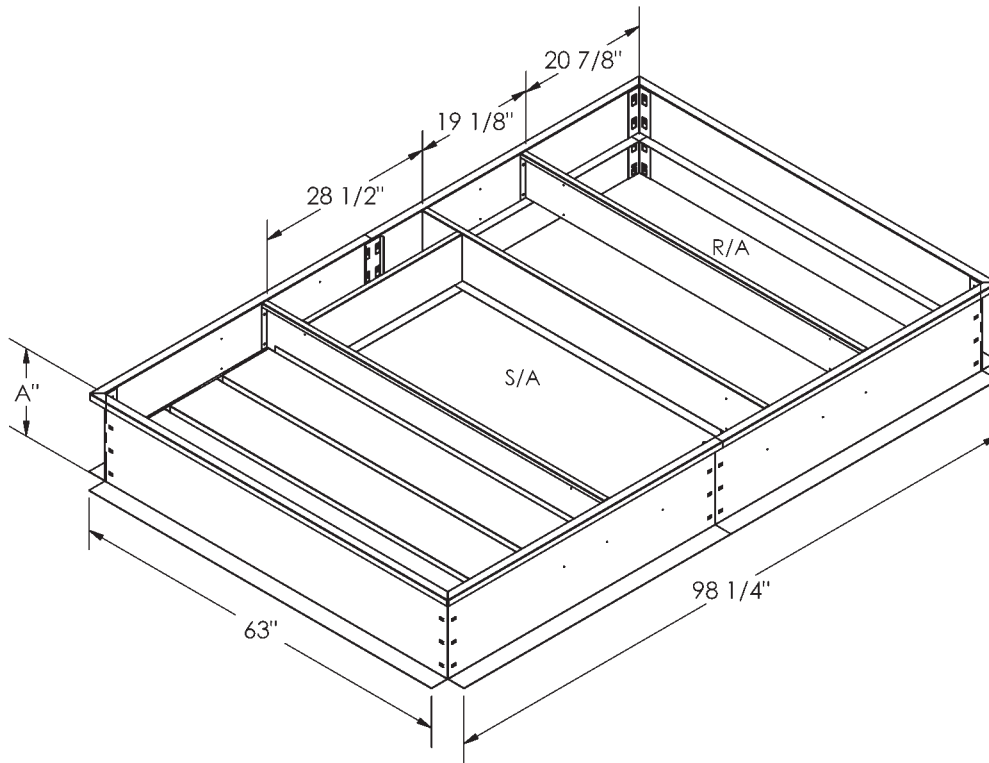

## FEATURES

- MITERED TOP CORNERS
- ROOF CURB IS FABRICATED OF 18GA G90 GALVANIZED STEEL
- FULL PERIMETER WOOD NAILER
- PRE-PUNCHED ASSEMBLY HOLES AND HARDWARE INCLUDED FOR DUCT SUPPORT INSTALLATION
- ROOF CURB IS SHIPPED UNASSEMBLED
- \* CURBS ARE INTERNALLY INSULATED WITH 1" THICK 1-1/2 LB DENSITY DUCT LINER

