

DATE: \_\_\_\_\_  
 COMPANY: \_\_\_\_\_  
 JOB NAME: \_\_\_\_\_  
 SUBMITTED BY: \_\_\_\_\_  
 NOTES: \_\_\_\_\_  
 \_\_\_\_\_

FLUSH MOUNT HARD DUCT  
 SUBMITTAL DATA FOR:  
**CARRIER UNITS**  
**48/50PG16**

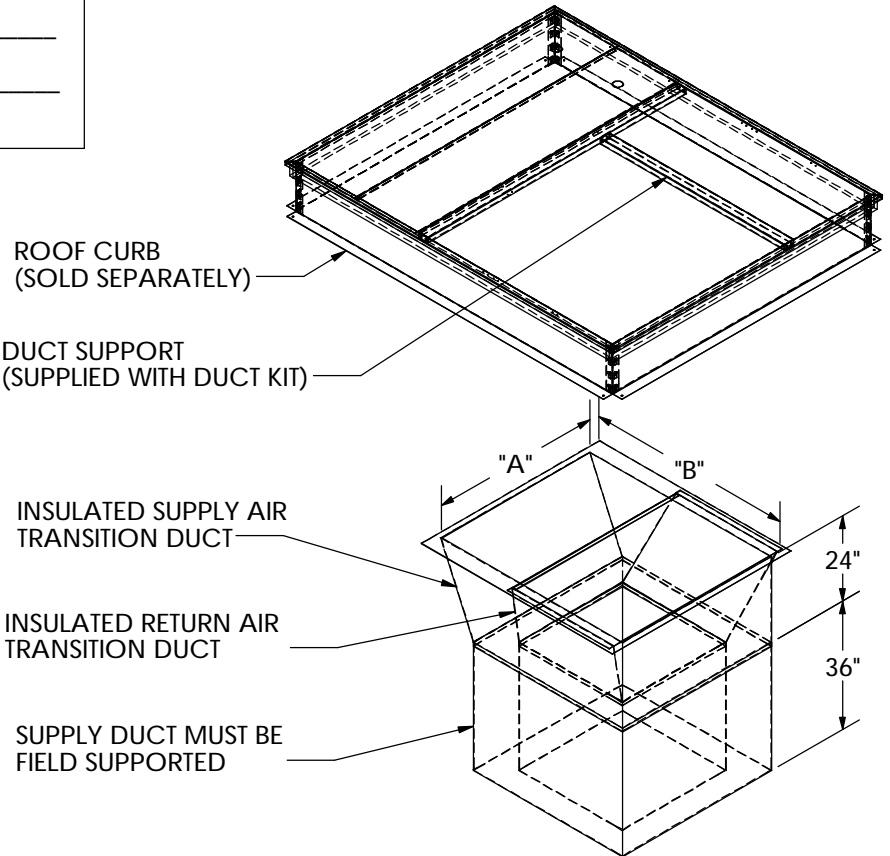

FEATURES:

FLUSH MOUNT PAINTED WHITE DIFFUSER GRILLE WITH FIXED BLADES

SUPPLY DUCT INSULATED WITH 1" INSULATION

RETURN DUCT INSULATED WITH 1/2" INSULATION

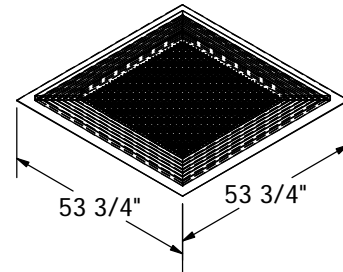

CAMBRIDGEPORT PART NUMBER	APPLICABLE CURB MODEL NUMBERS	"A"	"B"	DIFFUSER SIZE	RETURN GRILL	NOMINAL CFM	THROW IN FT.	
							MIN	MAX
1010441	CRRFCURB0034A00SL	54 1/4"	58 7/8"	48" X 48"	33" X 33"	6,000	28'	46'

NOTES:

- 1 - DO NOT INSTALL FACTORY SUPPLIED DUCT SUPPORTS UNLESS NOTED IN ASSEMBLY INSTRUCTIONS
- 2 - INSTALL CONCENTRIC DUCTWORK BEFORE SETTING A/C UNIT IN PLACE
- 3 - PLACE GASKETING ON ALL SURFACES OF DUCT FLANGE AND CURB
- 4 - ALIGN CARRIER UNIT SUPPLY OPENING TO MATCH SUPPLY OPENING OF CONCENTRIC DUCT KIT
- 5 - FIELD BAFFLES MAY BE REQUIRED FOR BALANCING
- 6 - FOR INSTALLATION SEE ASSEMBLY INSTRUCTIONS

Drawn By: CRF  
 Date: 2/13/08 Rev: 0

**Cambridgeport**  
**AIR SYSTEMS**

MEMPHIS, TN 38118

PHONE 1-877-648-2872 FAX 901-566-0035

SALISBURY, MA 01952

PHONE 1-800-648-2872 FAX 978-462-9189