

SUBMITTAL

CARRIER 38C

ADJ. CURB ASSEMBLY NUMBER

1012849

Drawn By: JBH
Drawn Date: 8-7-09

REV:

ESTIMATED WEIGHT: 289 LBS.

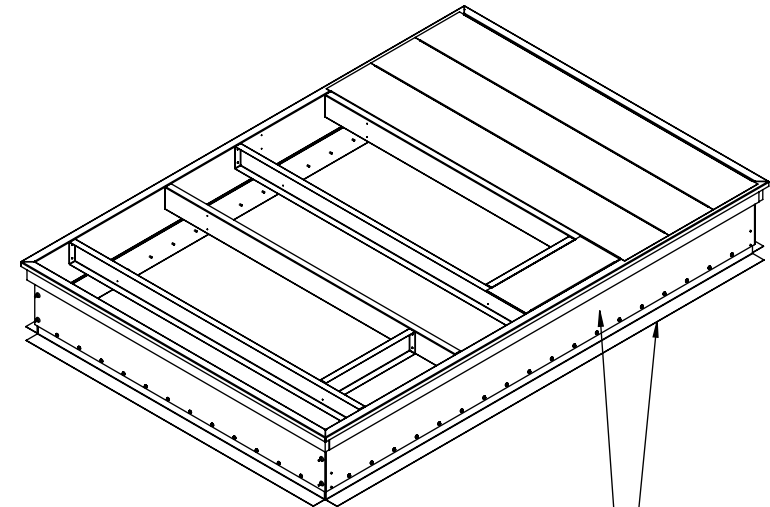
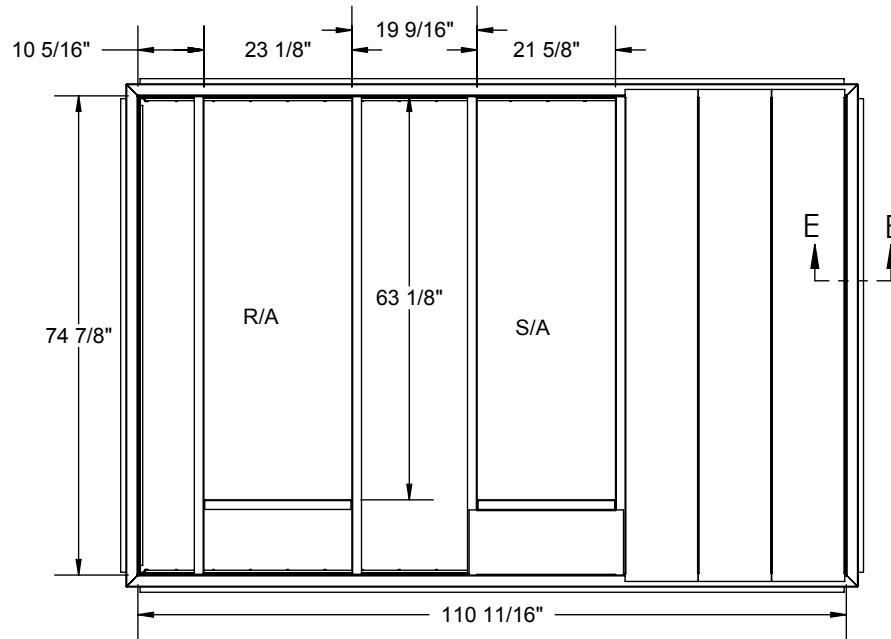

LOWER SECTION SLIDES INTO UPPER SECTION AND FASTENED EVERY 6 INCHES WITH TEK SCREWS SEE SHEET 2

FEATURES:

FULLY ADJUSTABLE HEIGHT AND PITCH UP TO 1" PER FOOT IN ANY DIRECTION

MITERED TOP CORNERS

ROOF CURB BODY IS FABRICATED OF HEAVY GAUGE GALVANIZED STEEL

FULL PERIMETER WOOD NAILER

PRE-PUNCHED ASSEMBLY HOLES AND HARDWARE INCLUDED FOR DUCT SUPPORT INSTALLATION

ROOF CURB IS SHIPPED KNOCKED DOWN

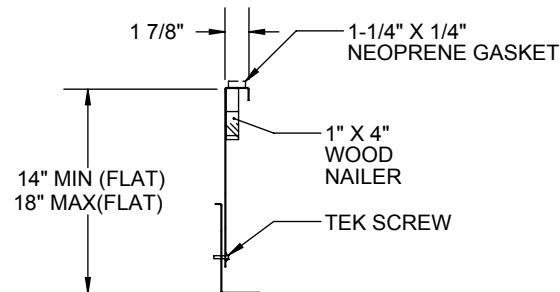

SECTION E-E

© 2007 COX ENGINEERING COMPANY
DBA CAMBRIDGEPORT AIR SYSTEMS. ALL RIGHTS RESERVED

Cambridgeport
AIR SYSTEMS, INC.

SALISBURY, MA 01952

PHONE 1-800-648-2872 FAX 1978-462-9189