

Cambridgeport

SUBMITTAL

SUBMITTED TO _____
 COMPANY _____
 JOB NAME _____
 EQUIPMENT _____
 SIGNATURE _____
 DATE _____

ROOF CURBS FOR ROOFTOP UNITS

Carrier; 48/50 TC 24-28

Bryant; 580J, 558J 240-300

CAS	PART #	BRY/CAR	PART #	INSULATED	CURB HEIGHT
					"A"
1014563		CRRFCURB047A00		1014852	14"
1014849				1014851	8"
1014850				1014853	18"
1014638		CRRFCURB048A00		1014854	24"

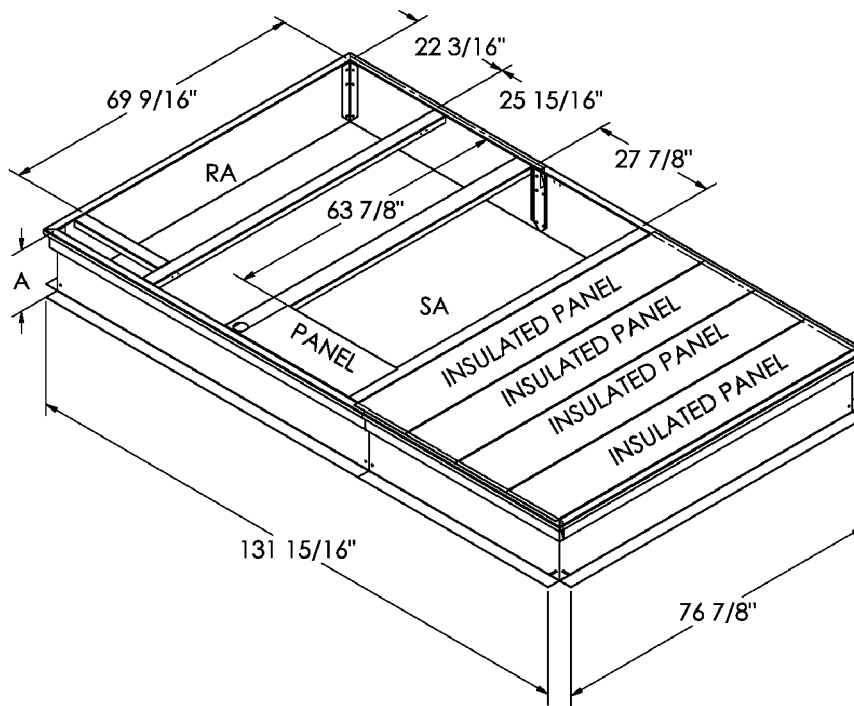

FEATURES

- MITERED TOP CORNERS
- ROOF CURB IS FABRICATED OF 18GA G90 GALVANIZED STEEL
- FULL PERIMETER WOOD NAILER
- PRE-PUNCHED ASSEMBLY HOLES AND HARDWARE INCLUDED FOR DUCT SUPPORT INSTALLATION
- ROOF CURB IS SHIPPED UNASSEMBLED
- * CURBS ARE INTERNALLY INSULATED WITH 1" THICK 1-1/2 LB DENSITY DUCT LINER

