

© 2007 COX ENGINEERING DBA CAMBRIDGEPORT AIR SYSTEMS.
 THE INFORMATION CONTAINED IN THIS DOCUMENT IS PROPRIETARY TO
 COX ENGINEERING COMPANY DBA CAMBRIDGEPORT AIR SYSTEMS.
 THIS DOCUMENT OR THE INFORMATION CONTAINED IN WHOLE OR IN PART
 MAY NOT BE ISSUED TO ANOTHER PARTY WITHOUT WRITTEN CONSENT AND
 AUTHORIZATION FROM CAMBRIDGEPORT.

Approval Block

Date: _____
 Company: _____
 Job Name: _____
 Approved By: _____
 Notes: _____

ROOF CURB SUBMITTAL # 1016199

LENNOX LGH 092-150

1016199

Drawn Date: 6/29/10 Rev. _____
 Drawn By: JBH
Estimated Weight: 18610 LBS.

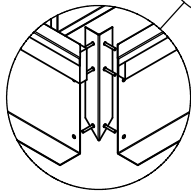
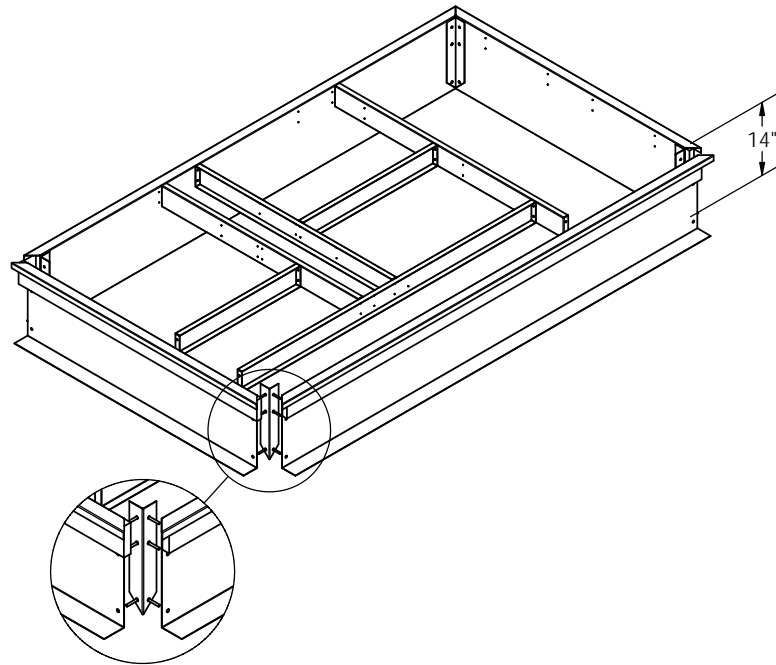

DETAIL A

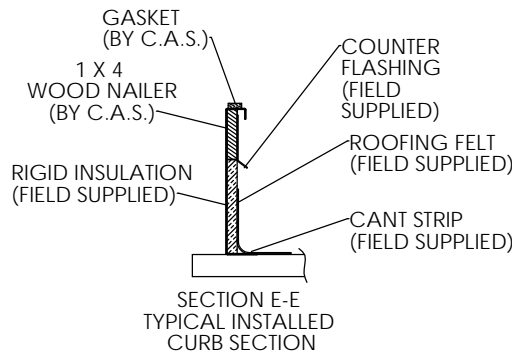
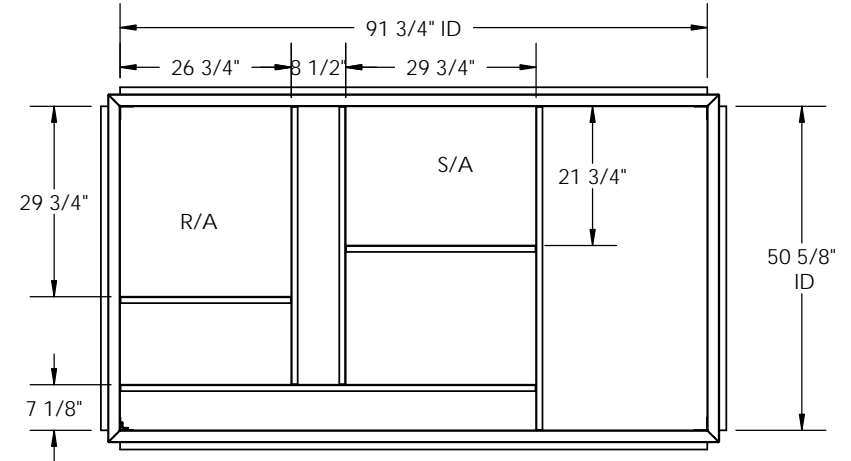

FEATURES:

1. Mitered Corners.
2. Gasketing Provided for Unit to Curb Sealing.
3. Roof Curb is Fabricated of Heavy Gauge Galvanized Steel.
4. Full Perimeter Wood Nailer.
5. Pre-Punched Holes and Hardware Included for Curb Assembly.
6. Roof Curb is Shipped Knocked Down.
7. Roof Curb is Labeled with RTU # if Applicable.

Cambridgeport

| | | |
|---|----------------------------------|---|
| NORTH 8 Fanaras Drive Salisbury Industrial Park Salisbury MA 01952 | 1-800-648-2872 1-877-648-2872 | SOUTH 3529 Lamar Ave. Lamar Industrial park Memphis TN 38118 |
|---|----------------------------------|---|

HVAC Accessories & Engineered Systems