

DATE: _____
 COMPANY: _____
 JOB NAME: _____
 SUBMITTED BY: _____
 NOTES: _____

INSTALL NEW DUCT SUPPORT
& PANEL
(PROVIDED WITH DUCT KIT)

DUCT SUPPORT
(SUPPLIED WITH CURB)

REMOVE

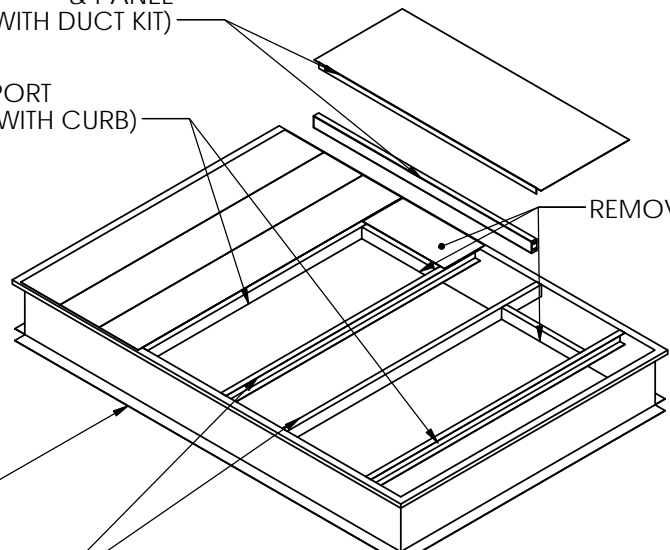

**DROP BOX HARD DUCT
 SUBMITTAL DATA FOR:**

**CARRIER UNIT
 48PM16**

ROOF CURB
(SOLD SEPARATELY)

REMOVE

INSULATED SUPPLY AIR
TRANSITION DUCT

INSULATED RETURN AIR
TRANSITION DUCT

SUPPLY DUCT MUST BE
FIELD SUPPORTED

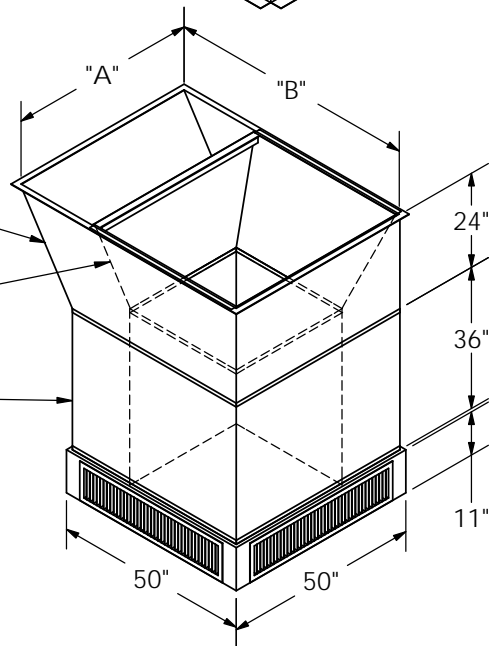

FEATURES:

DROP BOX SHIPPED ASSEMBLED, INSULATED WITH 1" INSULATION
 PAINTED WHITE WITH DOUBLE DEFLECTION SUPPLY GRILLES
 AND EGG CRATE RETURN

SUPPLY DUCT INSULATED WITH 1" INSULATION

RETURN DUCT INSULATED WITH 1/2" INSULATION

| CAMBRIDGEPORT PART NUMBER | APPLICABLE CURB MODEL NUMBERS | "A" | "B" | SUPPLY GRILL | RETURN GRILL | NOMINAL CFM | THROW IN FT. | |
|------------------------------|--|---------|---------|-----------------|-----------------|----------------|-----------------|-----|
| | | | | | | | MIN | MAX |
| 1017161 | 48PM16 | 48 1/4" | 63 3/8" | (4)-40 X 8 | 32" X 32" | 6,000 | 28' | 70' |

NOTES:

- 1 - DO NOT INSTALL FACTORY SUPPLIED DUCT SUPPORTS UNLESS NOTED IN ASSEMBLY INSTRUCTIONS
- 2 - INSTALL CONCENTRIC DUCTWORK BEFORE SETTING A/C UNIT IN PLACE
- 3 - PLACE GASKETING ON ALL SURFACES OF DUCT FLANGE AND CURB
- 4 - ALIGN TRANE UNIT SUPPLY OPENING TO MATCH SUPPLY OPENING OF CONCENTRIC DUCT KIT
- 5 - FIELD BAFFLES MAY BE REQUIRED FOR BALANCING
- 6 - FOR INSTALLATION SEE ASSEMBLY INSTRUCTIONS

Drawn By: CDM
 Date: 12/6/10 Rev: 0

**Cambridgeport
 AIR SYSTEMS**

MEMPHIS, TN 38118

PHONE 1-877-648-2872 FAX 901-566-0035

SALISBURY, MA 01952

PHONE 1-800-648-2872 FAX 978-462-9189