

# Cambridgeport

## SUBMITTAL

SUBMITTED TO \_\_\_\_\_  
 COMPANY \_\_\_\_\_  
 JOB NAME \_\_\_\_\_  
 EQUIPMENT \_\_\_\_\_  
 SIGNATURE \_\_\_\_\_  
 DATE \_\_\_\_\_

## ISOLATION CURBS FOR BRYANT ROOFTOP UNITS

558J30 ; 551J28  
 580J30 ; 581J28

## ISOLATION CURBS FOR CARRIER ROOFTOP UNITS

48/50HC 28  
 48/50TC 30

DESCRIPTION	PART#
1" Deflection	1018297
2" Deflection	1018298

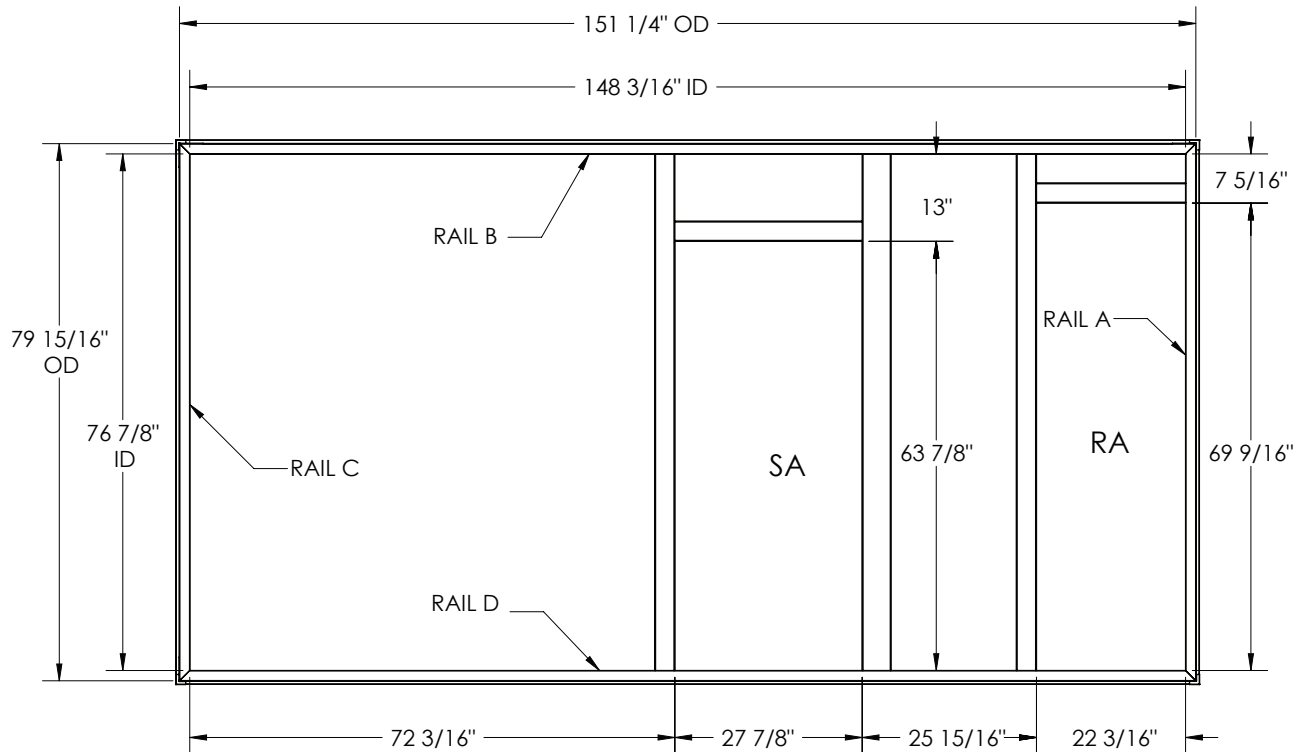

## FEATURES

- ASSEMBLED TO SUPPLIED ROOF CURB
- MITERED TOP CORNERS
- FABRICATED OF HEAVY GALVANIZED STEEL
- FULL PERIMETER WEATHER SEAL
- 1" OR 2" STATIC DEFLECTION
- DUCT SUPPORTS INCLUDED
- CANVAS DUCT CONNECTIONS (NOT INCLUDED)

